



Intermediate deck coating system  
**Triflex DeckCoat**

## System drawings

Surface

### System build-up – Detail A

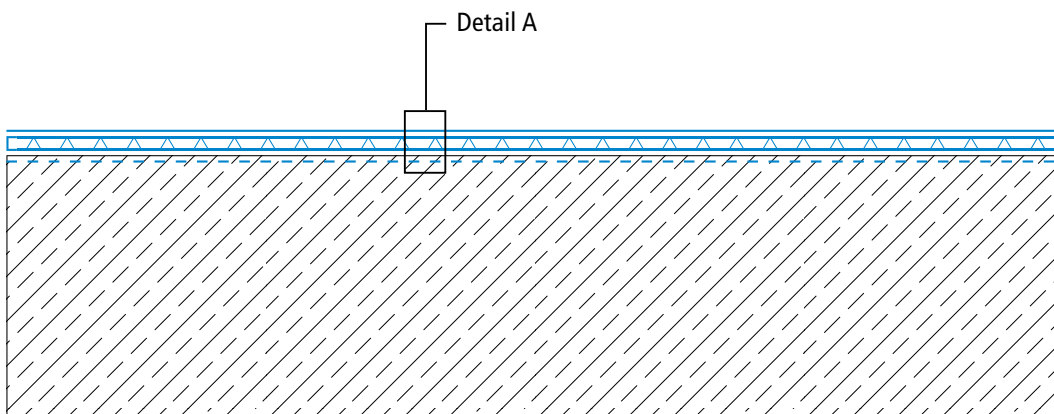
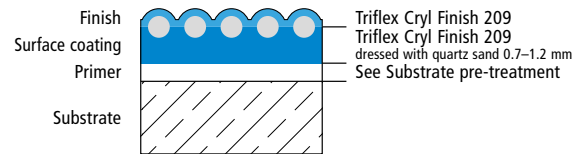

Intermediate deck coating system  
**Triflex DeckCoat**



## System drawings

### Wall junction

#### System build-up – Detail A

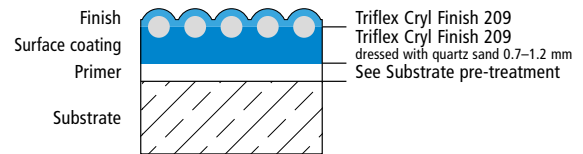

#### System build-up – Detail C

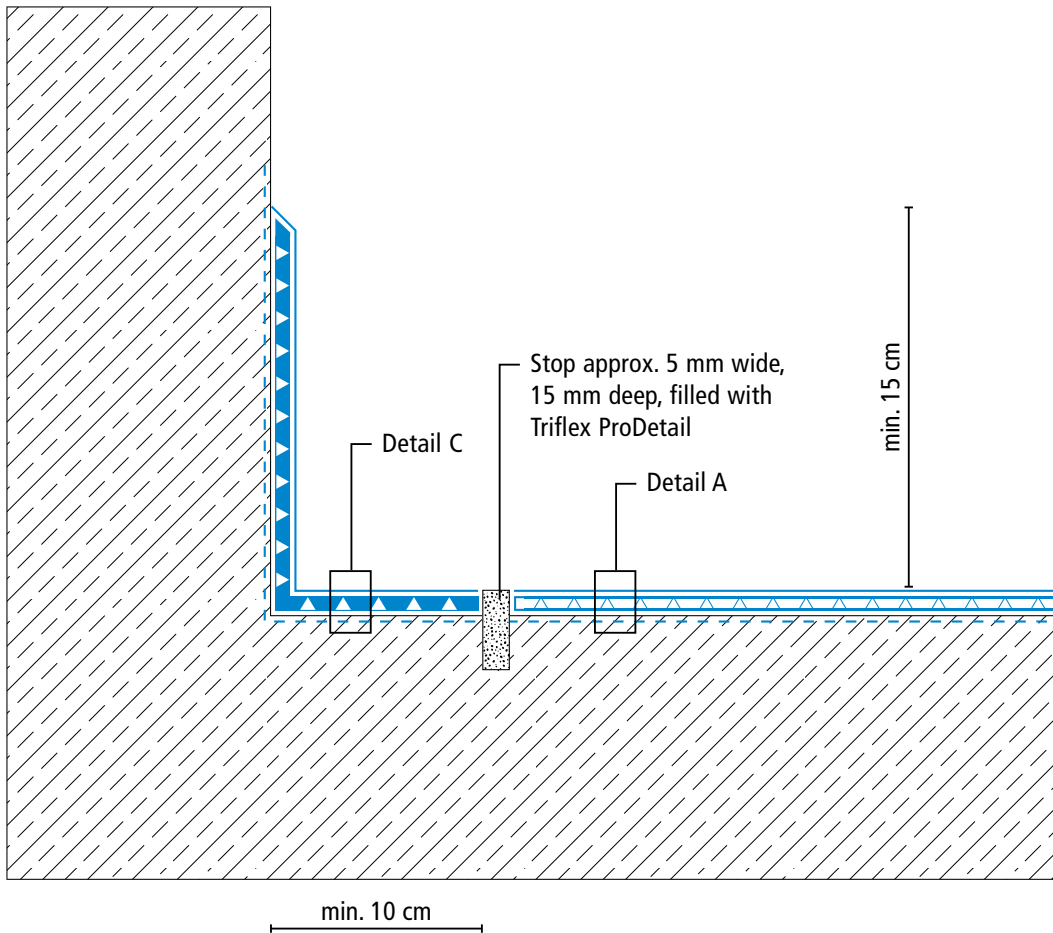
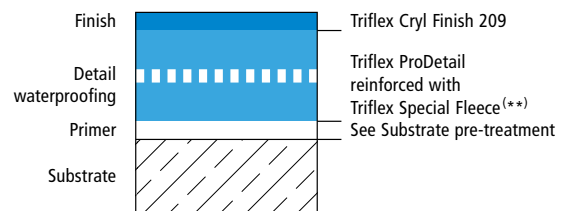

Intermediate deck coating system  
**Triflex DeckCoat**



## System drawings

### Prop connector

#### System build-up – Detail A

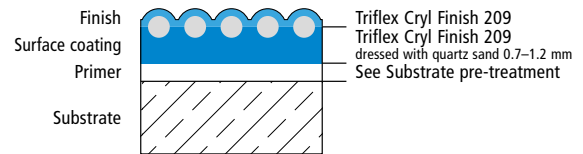

#### System build-up – Detail C

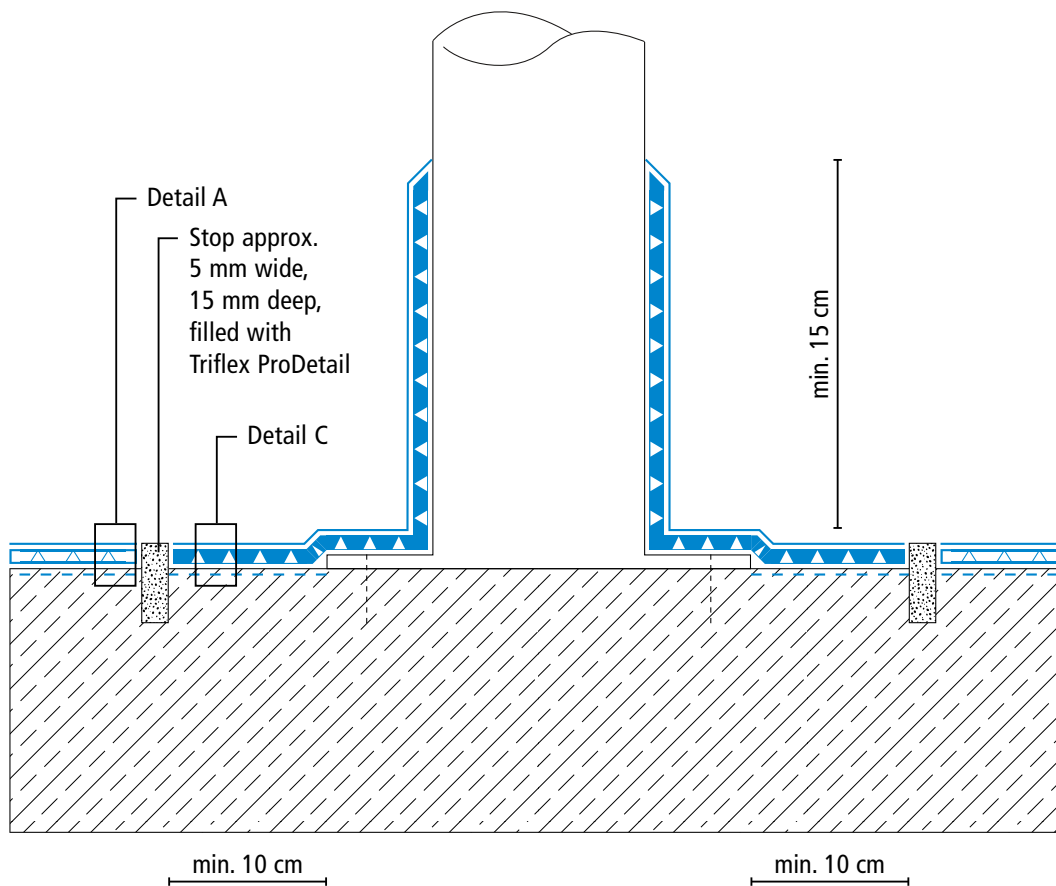
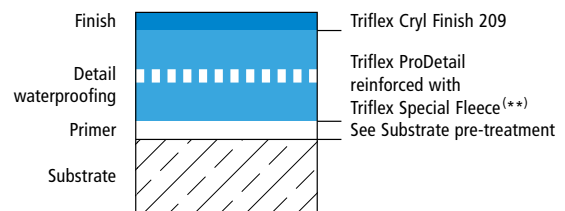

Intermediate deck coating system  
**Triflex DeckCoat**



## System drawings

Kerb

### System build-up – Detail A

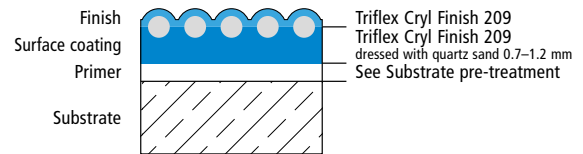

### System build-up – Detail C

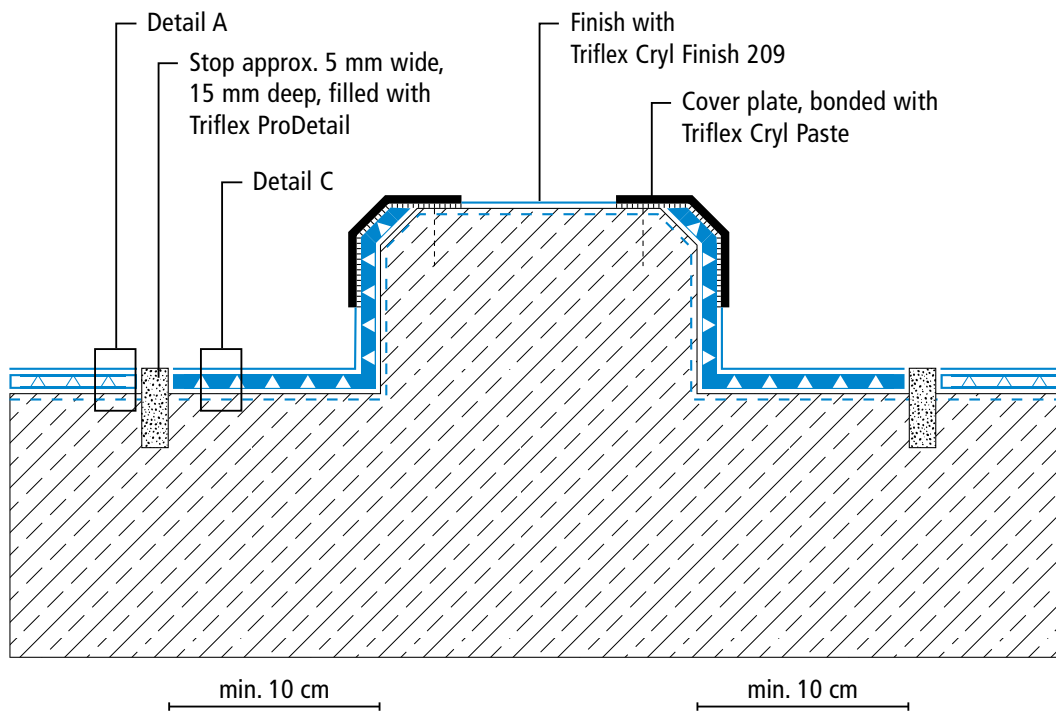
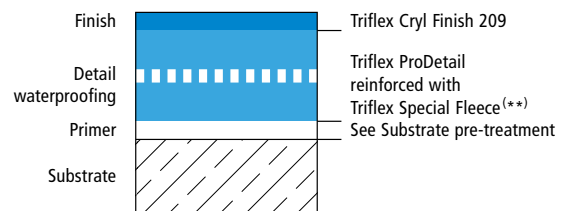

Intermediate deck coating system  
**Triflex DeckCoat**



## System drawings

### Gully

#### System build-up – Detail A

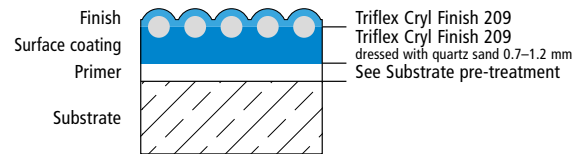

#### System build-up – Detail B

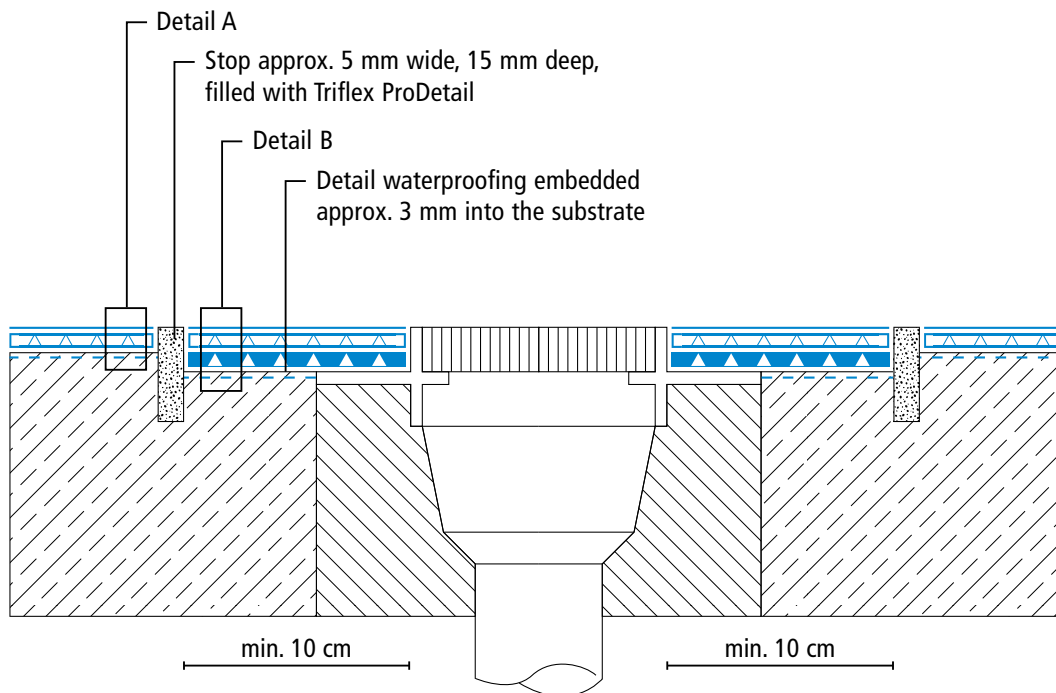
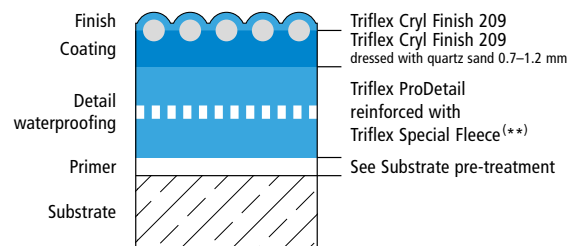

(\*\*) Triflex Special Fleece or Triflex Special Fleece PF  
 Height differences where the fleece overlaps are exaggerated.



# Intermediate deck coating system Triflex DeckCoat

## System drawings

### Construction joint

#### System build-up – Detail A

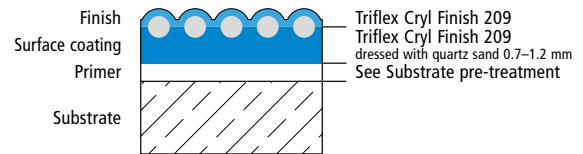

#### System build-up – Detail B

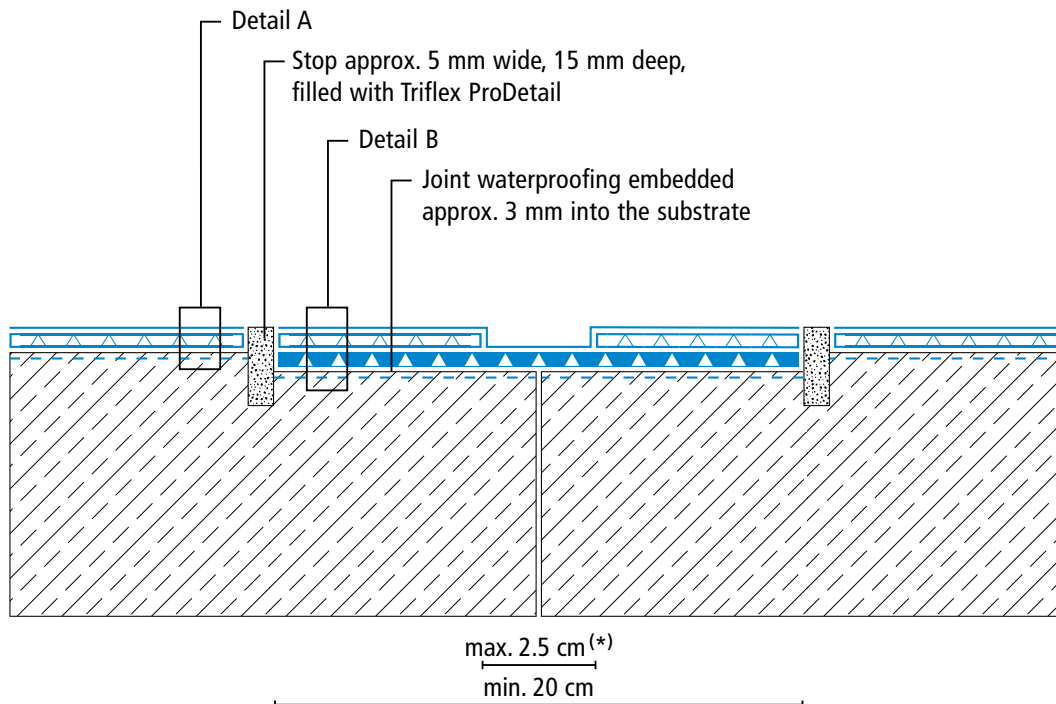
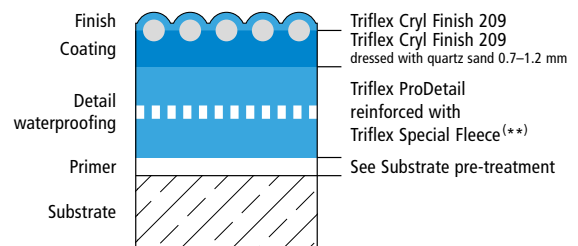

(\*) Omission of coating (see system description)

(\*\*) Triflex Special Fleece or Triflex Special Fleece PF

Height differences where the fleece overlaps are exaggerated.

Intermediate deck coating system  
**Triflex DeckCoat**



## System drawings

### Expansion joint surface

#### System build-up – Detail A

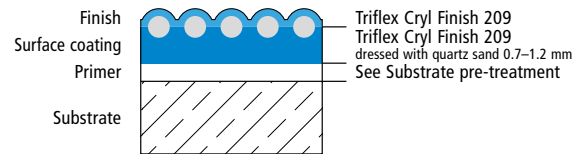

#### System build-up – Detail D

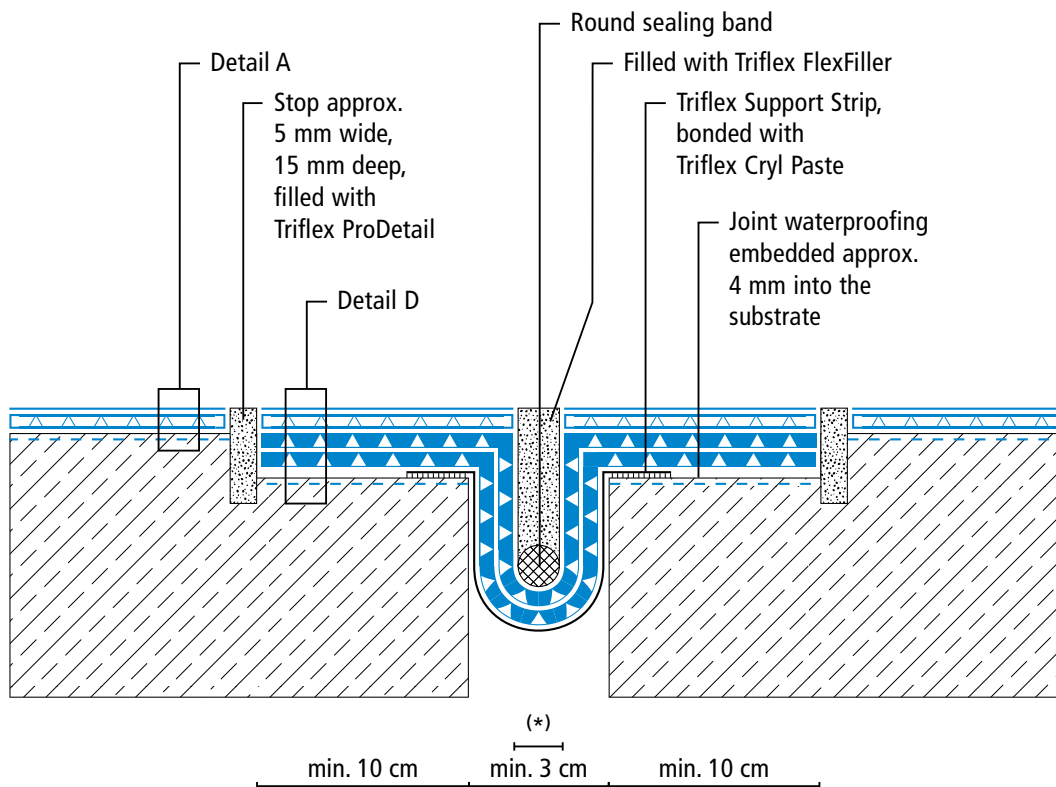
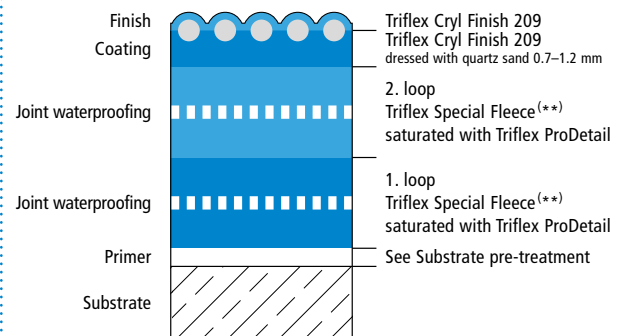

(\*) Omission of coating and finish (see system description)

(\*\*) Triflex Special Fleece or Triflex Special Fleece PF

Height differences where the fleece overlaps are exaggerated.



# Intermediate deck coating system Triflex DeckCoat

## System drawings

### Expansion joint – wall junction

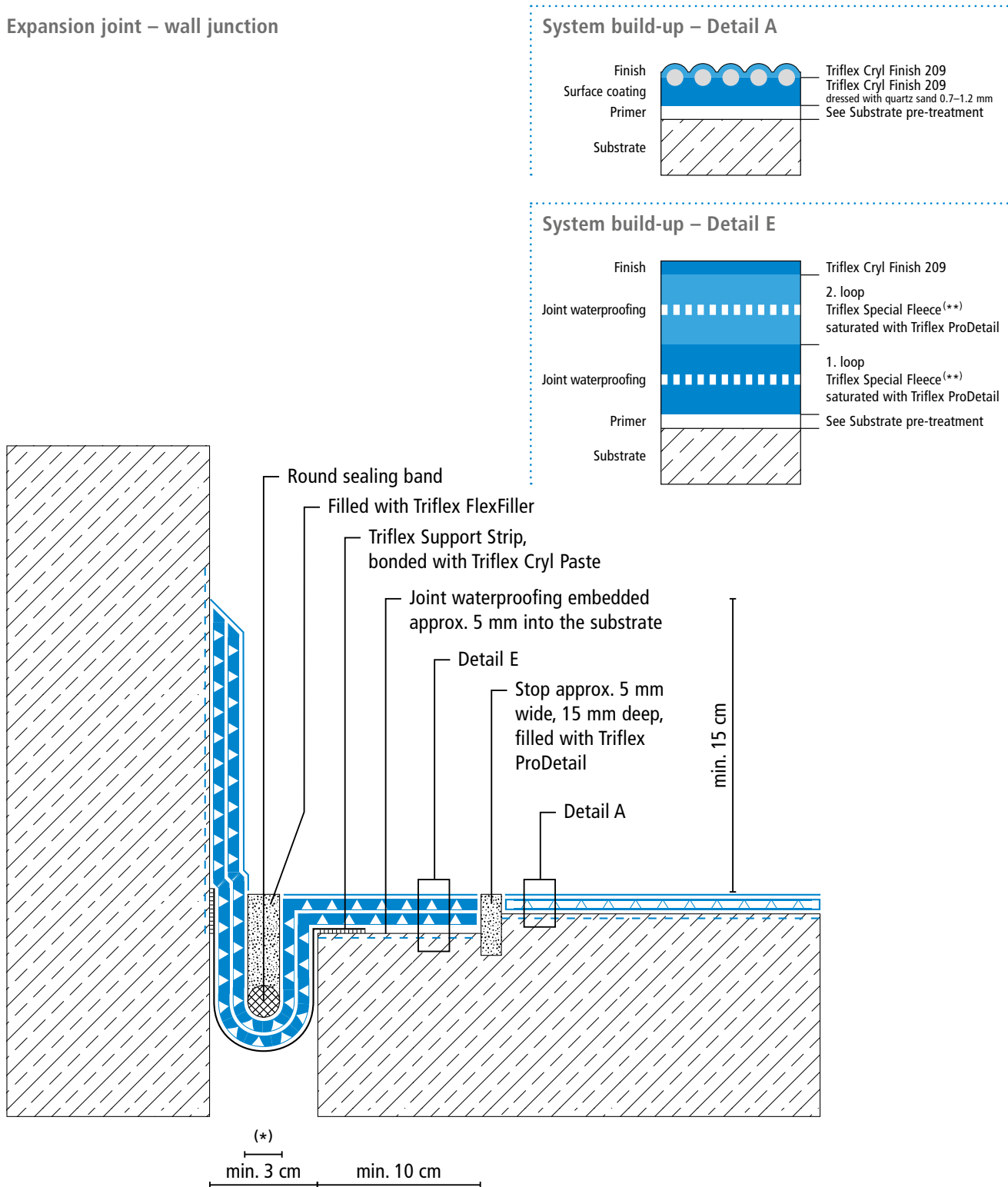

(\*) Omission of finish (see system description)

(\*\*) Triflex Special Fleece or Triflex Special Fleece PF

Height differences where the fleece overlaps are exaggerated.