



Parking deck coating system (OS 11a/b)

Triflex ProDeck Variation 1

System drawings

Surface

System build-up – Detail A

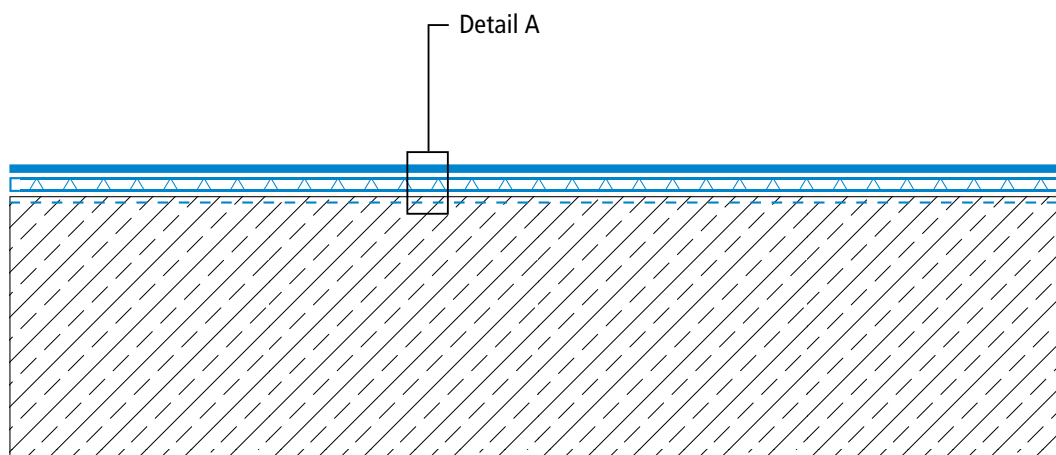
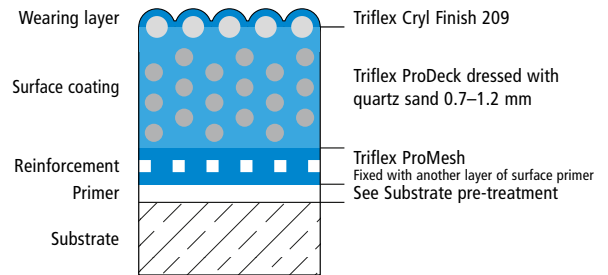

Drawing no.: ProDeck-1101

Triflex ProDeck Variation 1



System drawings

Wall junction

System build-up – Detail C

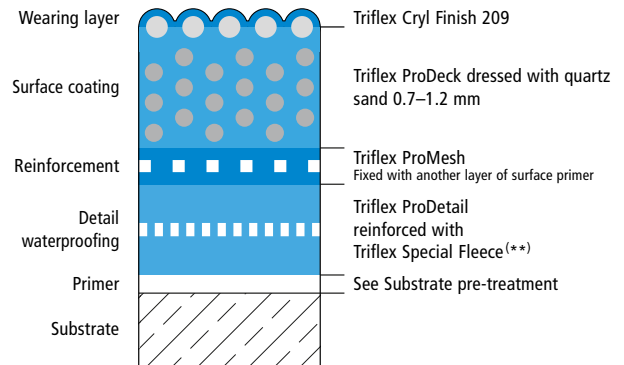

(**) Triflex Special Fleece or Triflex Special Fleece PF
Height differences where the fleece overlaps are exaggerated.

Triflex ProDeck Variation 1



System drawings

Prop connector

System build-up – Detail C

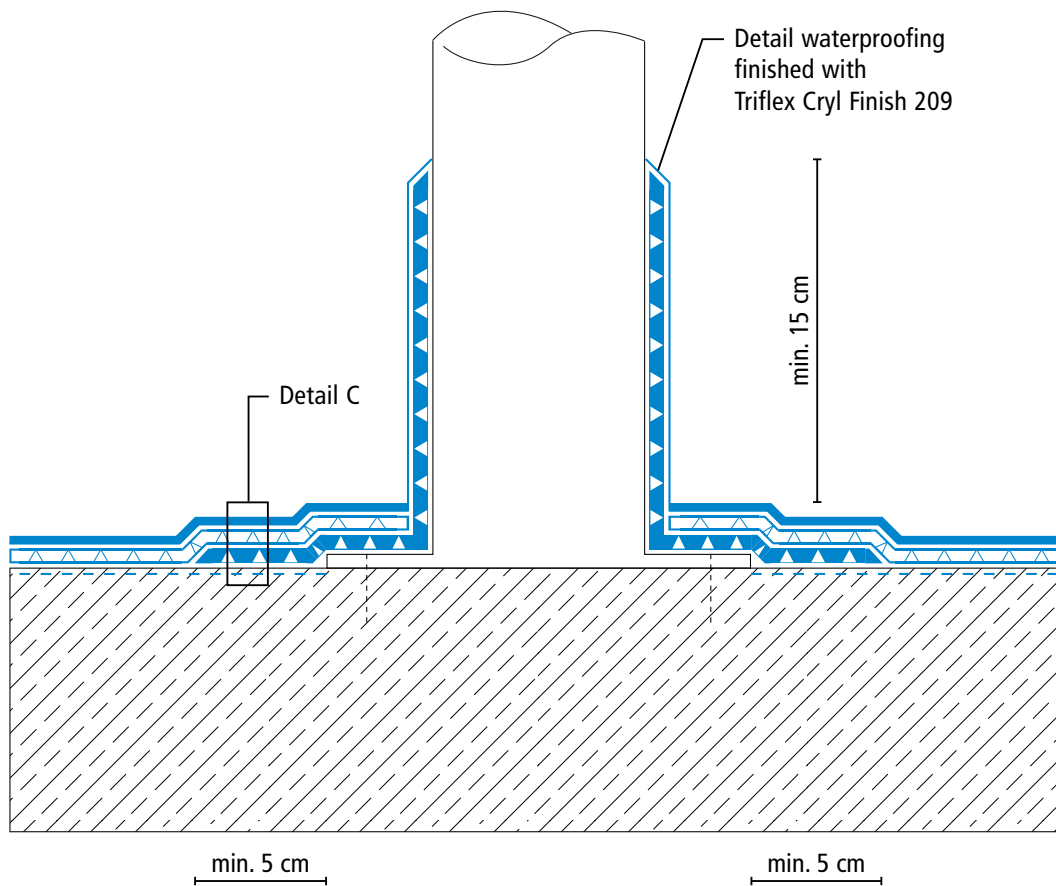
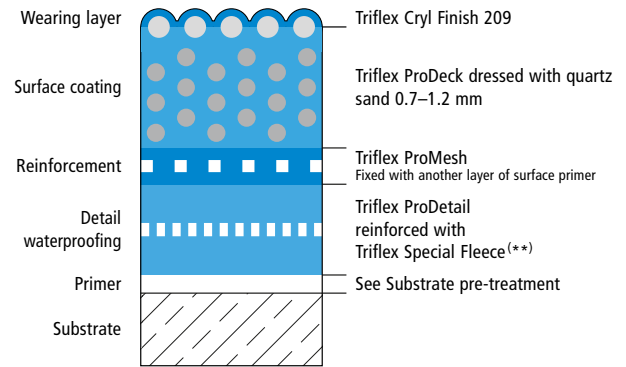

(**) Triflex Special Fleece or Triflex Special Fleece PF

Height differences where the fleece overlaps are exaggerated.

Triflex ProDeck Variation 1



System drawings

Kerb

System build-up – Detail C

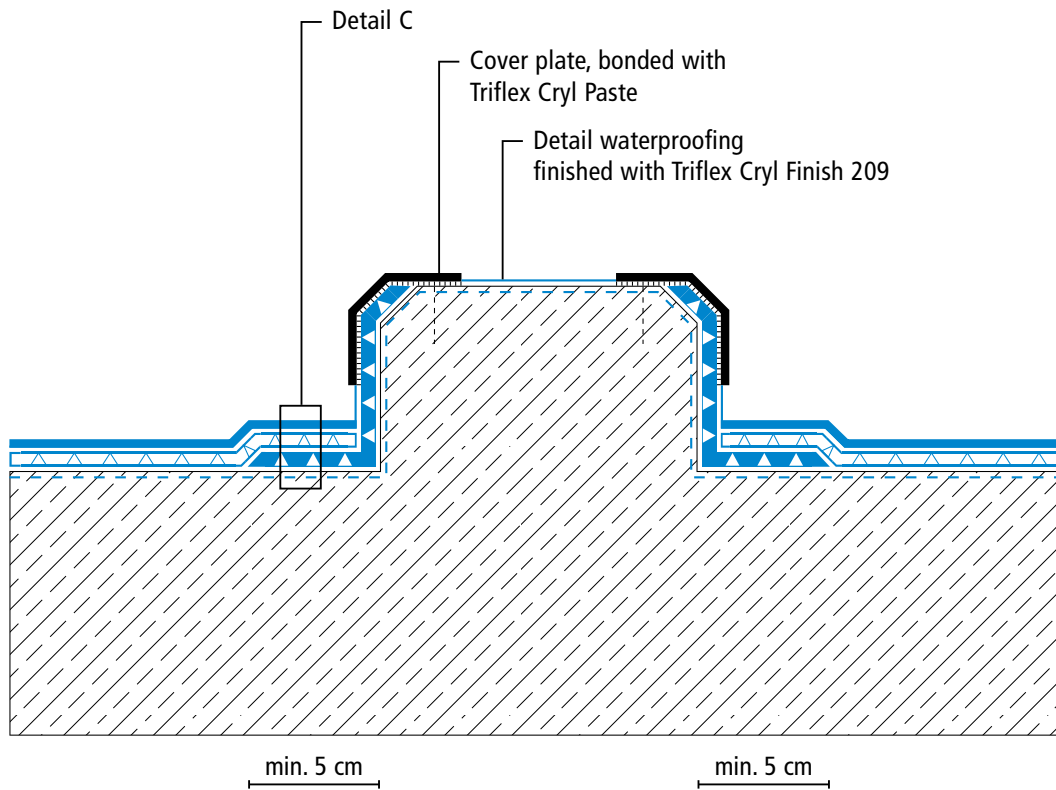
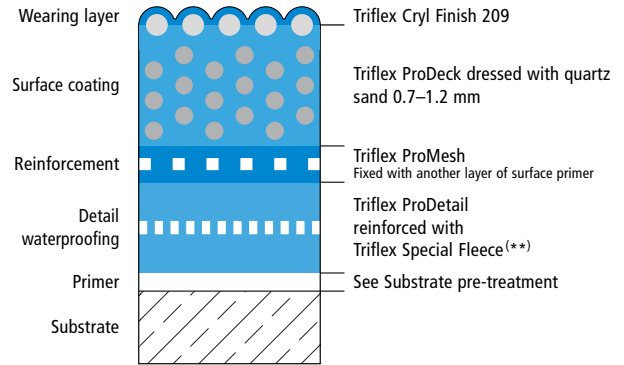

(**) Triflex Special Fleece or Triflex Special Fleece PF
Height differences where the fleece overlaps are exaggerated.



Parking deck coating system (OS 11a/b)

Triflex ProDeck Variation 1

System drawings

Gully/Gutter

System build-up – Detail C

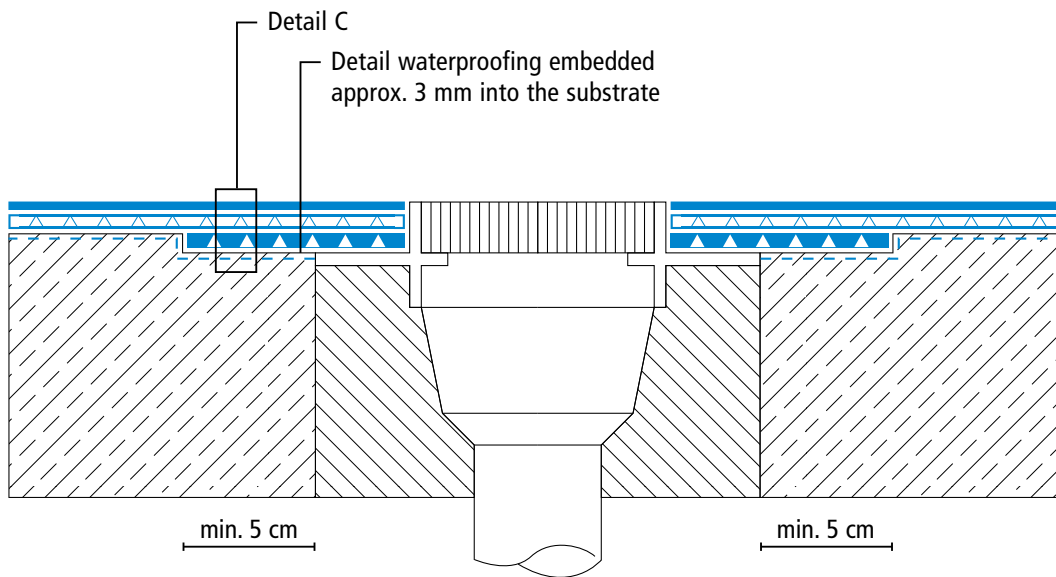
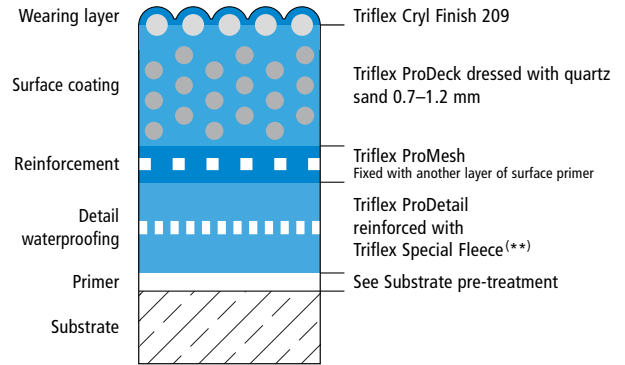

(**) Triflex Special Fleece or Triflex Special Fleece PF

Height differences where the fleece overlaps are exaggerated.

Drawing no.: ProDeck-1105

Triflex ProDeck Variation 1



System drawings

Construction joint

System build-up – Detail A

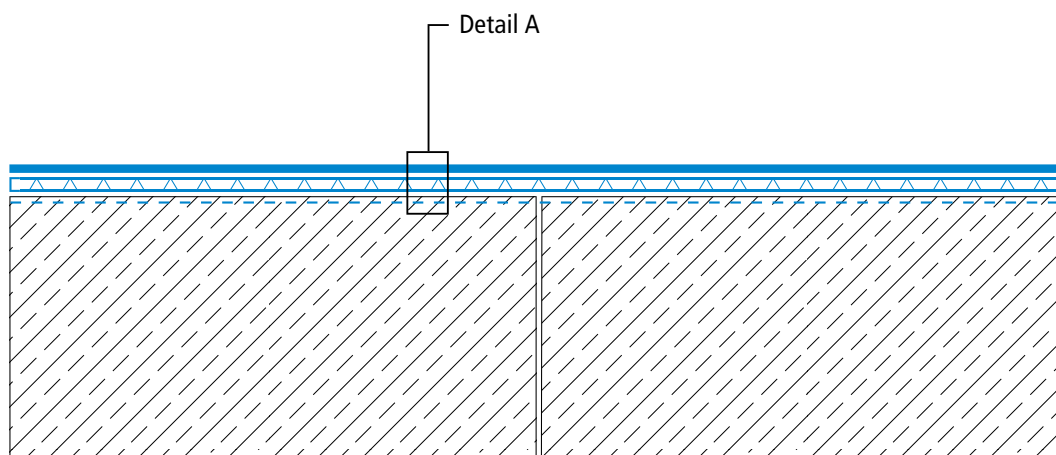
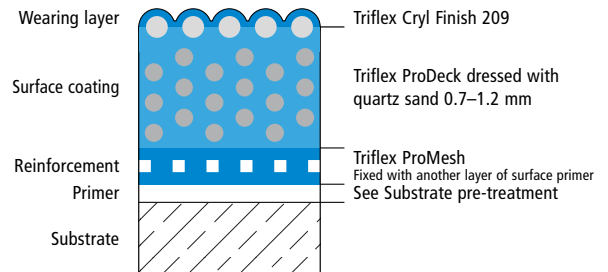

Triflex ProDeck Variation 1



System drawings

Expansion joint surface

System build-up – Detail E

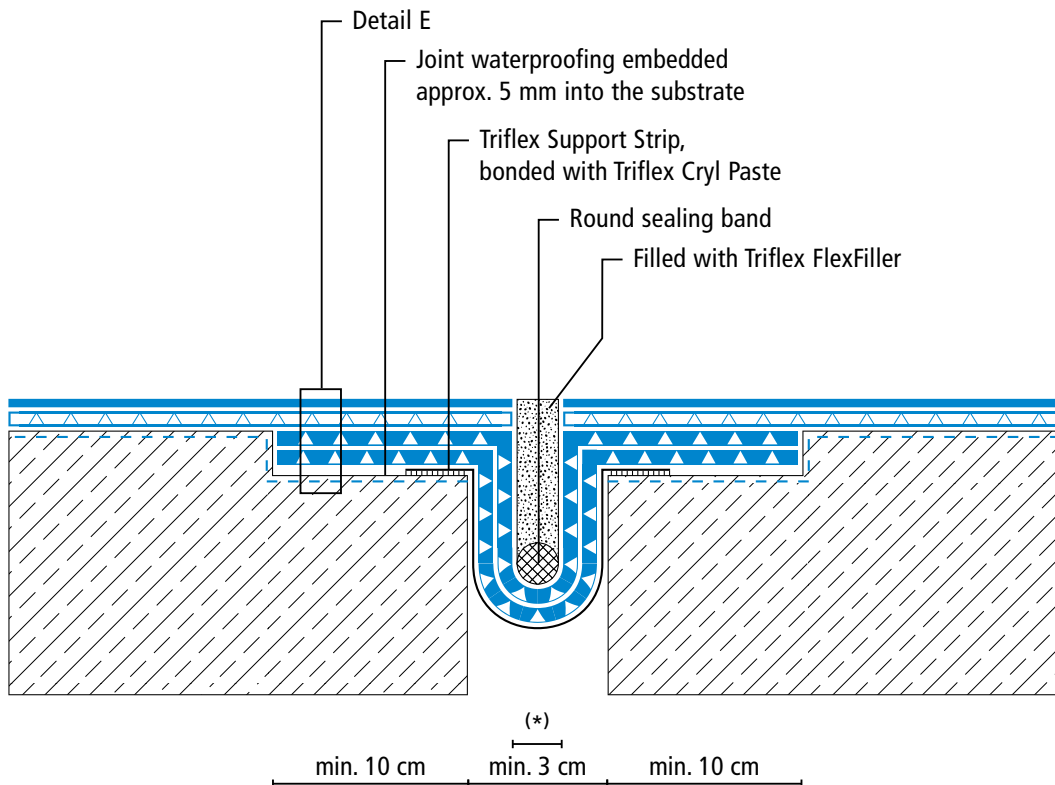
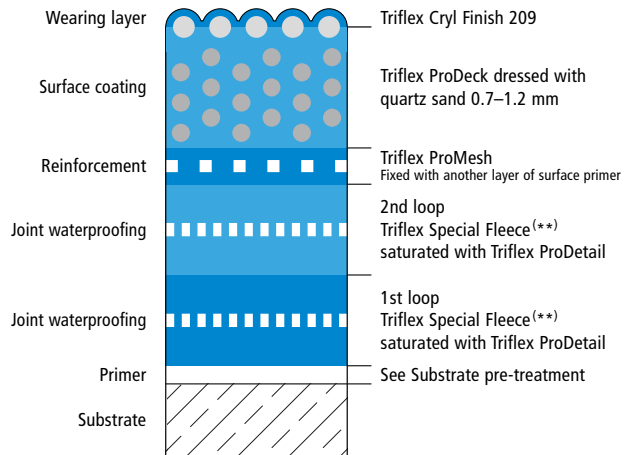

(*) Omission of surface coating and wearing layer (see system description)

(**) Triflex Special Fleece or Triflex Special Fleece PF

Height differences where the fleece overlaps are exaggerated.

Triflex ProDeck Variation 1



System drawings

Expansion joint – wall junction

System build-up – Detail E

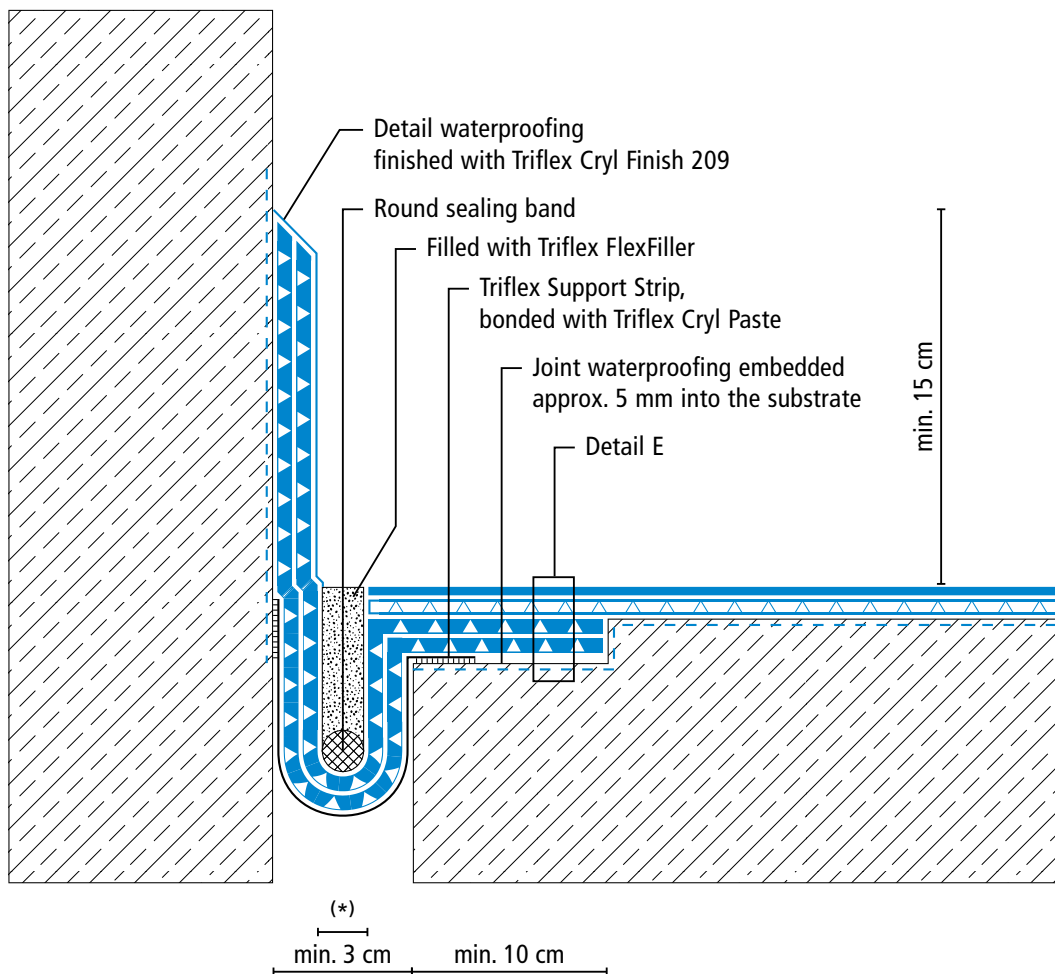
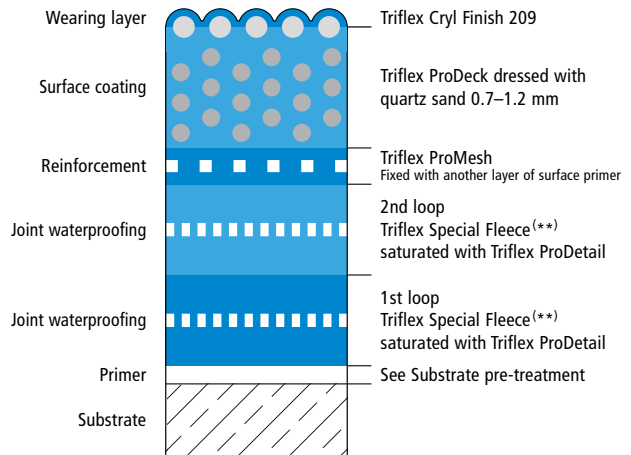

(*) Omission of surface coating and wearing layer (see system description)

(**) Triflex Special Fleece or Triflex Special Fleece PF

Height differences where the fleece overlaps are exaggerated.