

Trattamento per fessure Triflex Variante 1



Disegni del sistema

Trattamento per fessure, variante 1

Struttura del sistema, variante 1 – Dettaglio A

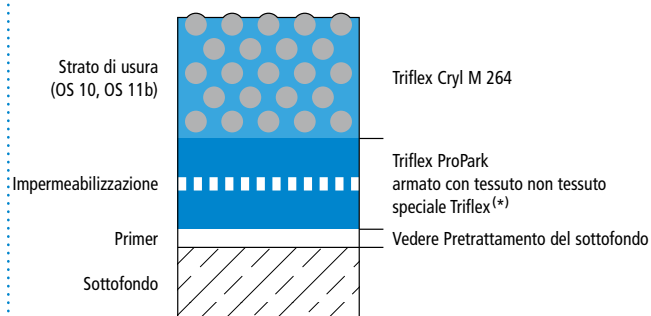

Struttura del sistema, variante 1 – Dettaglio B

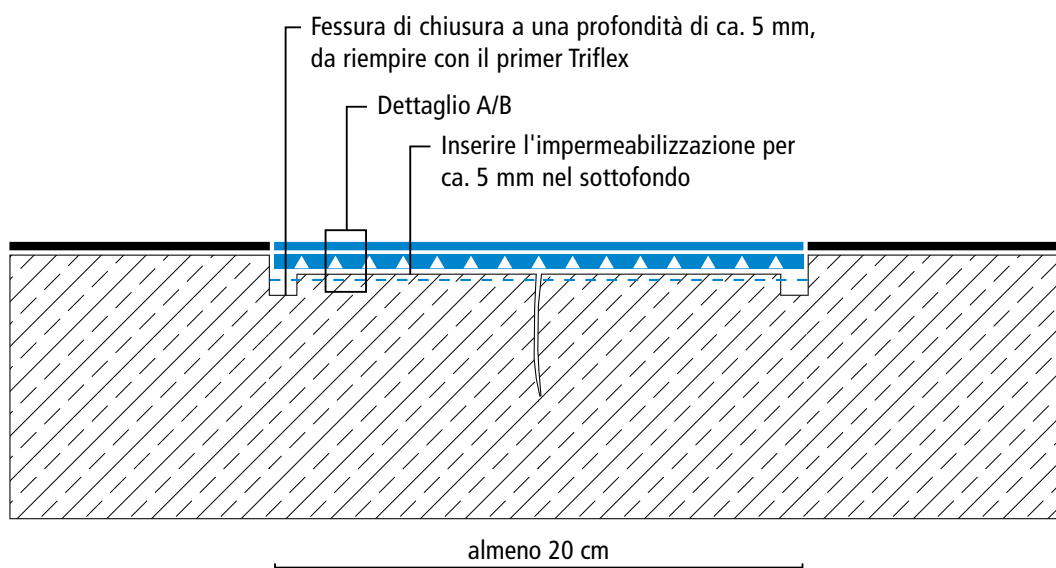
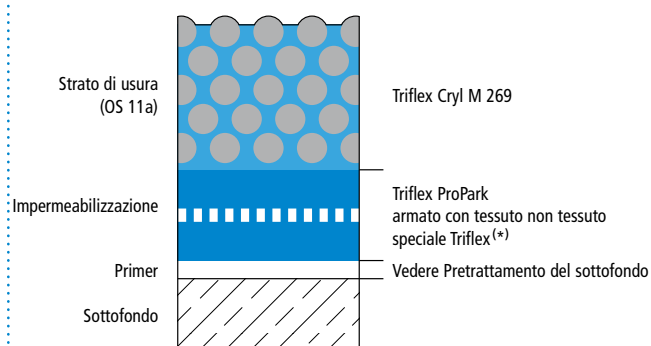

(*) Tessuto non tessuto speciale Triflex o tessuto non tessuto speciale Triflex PF.



Sistema d'impermeabilizzazione parziale (OS 10, OS 11a/b)

Trattamento per fessure Triflex Variante 2

Disegni del sistema

Trattamento per fessure, variante 2

Struttura del sistema, variante 2 – Dettaglio C

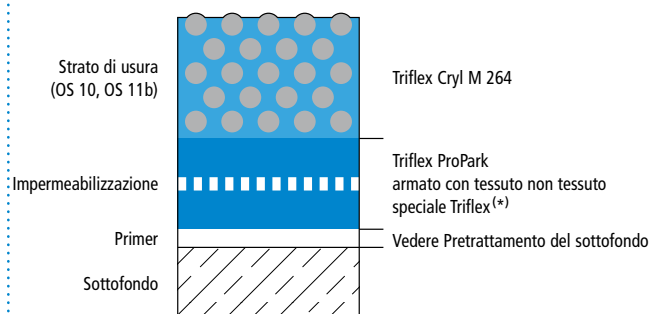

Struttura del sistema, variante 2 – Dettaglio D

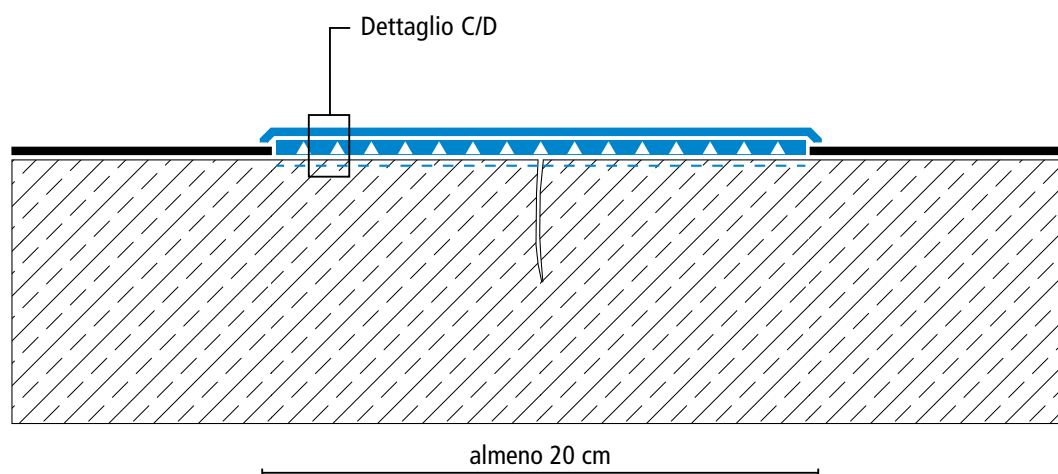
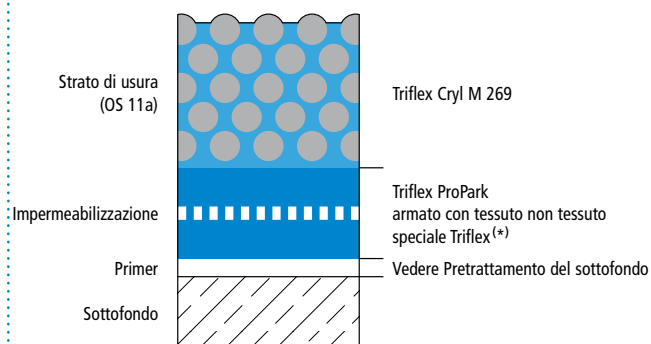

(*) Tessuto non tessuto speciale Triflex o tessuto non tessuto speciale Triflex PF.

Trattamento per fessure Triflex Variante 3



Disegni del sistema

Trattamento per fessure, variante 3

Struttura del sistema, variante 3 – Dettaglio E

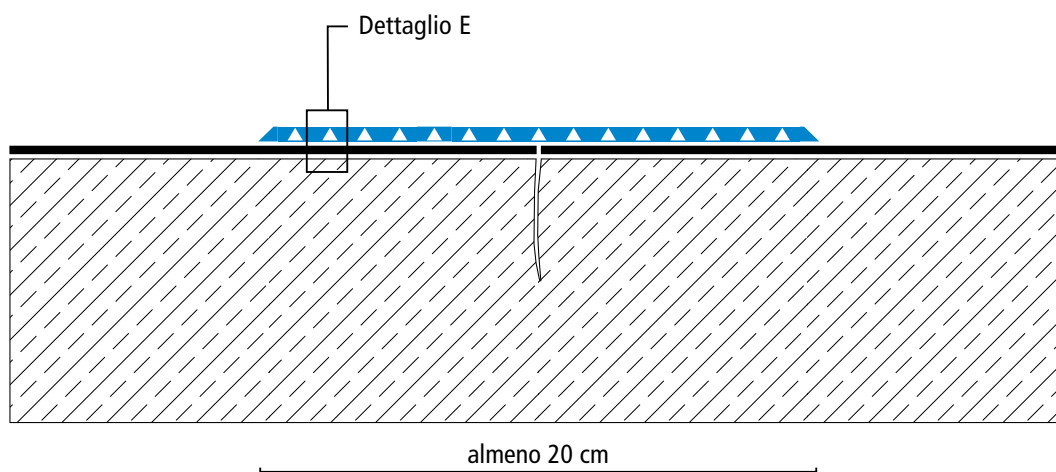
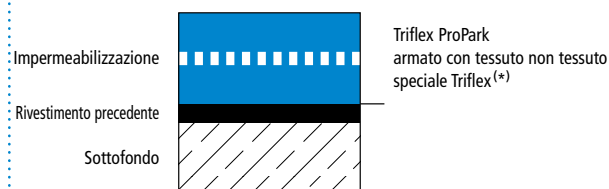

(*) Tessuto non tessuto speciale Triflex o tessuto non tessuto speciale Triflex PF.